

## ATTACHMENTS >>

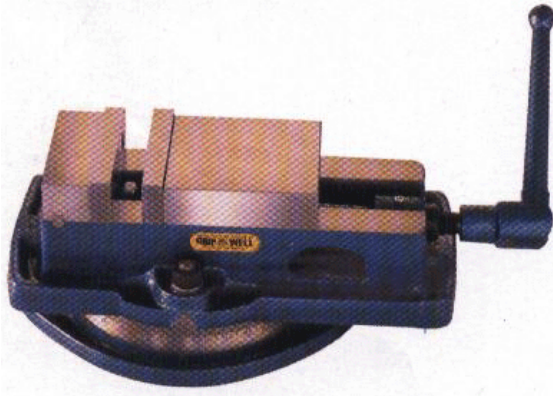

### MILLING MACHINE VICE

**Features :** Precision vice for milling machine with hardened slide ways and jaws, smoothly operated by heavy lead screw. Swivel calibrated base.

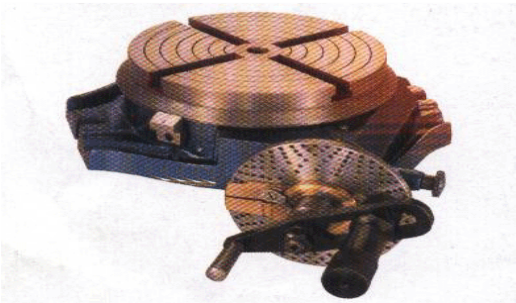

### ROTARY TABLE

**Features :** Precision round turn-table with indexing arrangement. Table is T-slotted with calibrated swivel base.

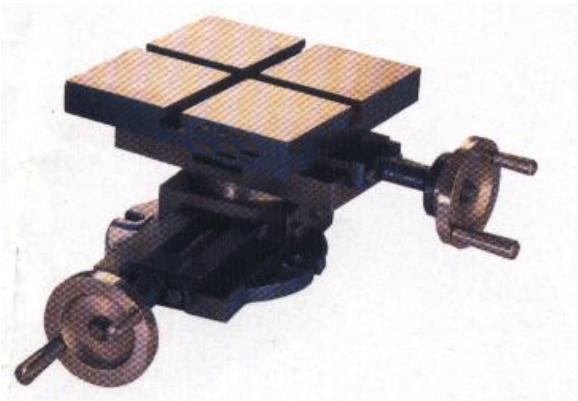

### COMPOUND SLIDE

**Features :** Work table T-slotted capable of 2-axes movement. With/without rotary function.

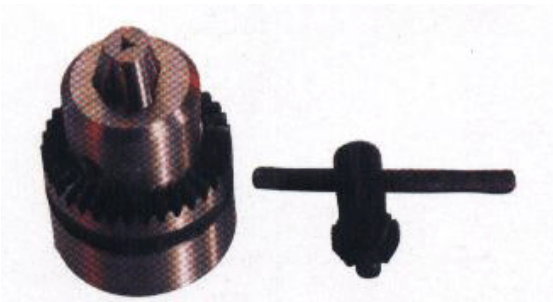

### DRILL CHUCK

**Features :** Available in 10, 12, 16, 20 and 25 mm size with various tapers.

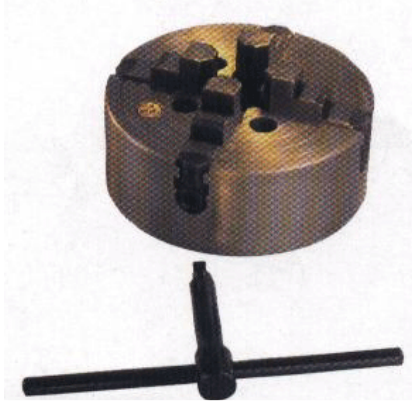

#### **4 JAW INDEPENDENT CHUCK (DOG CHUCK)**

**Features :** Available in 100, 125, 160, 200 mm upto 1250 mm size.

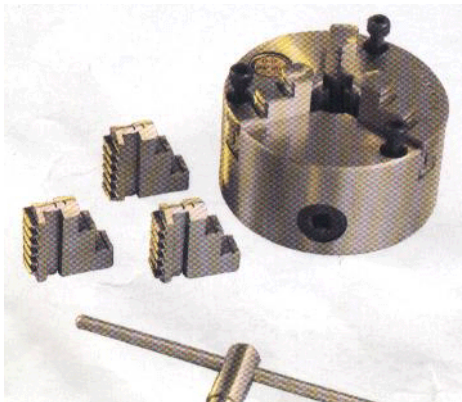

#### **3 JAW SELF CENTRING CHUCK (TRUE CHUCK)**

**Features :** Available in 100, 125, 160, 200 mm upto 500 mm size, with reverse jaw set.



#### **FLY PRESS**

**Features :** Fly wheel operated manual press available from 1 ton to 15 ton capacities and single/double body structure type.



#### **BUFFING MACHINE**

**Features :** Double ended high speed polishing machine available from 0.5 HP to 20 HP



#### **BENCH GRINDER**

**Features :** Double ended high speed stone grinders fitted with 2 grinding wheels. Available from 0.25 HP to 20 HP with various sizes of grinding stones available in various grits.

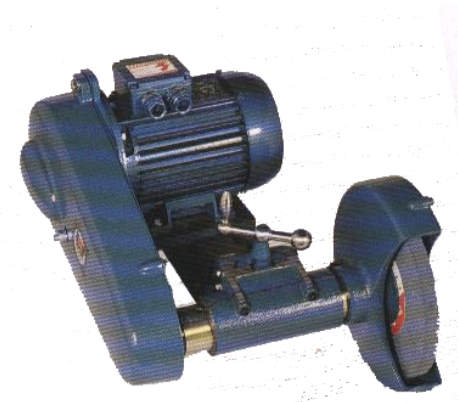

#### **TOOL POST GRINDER**

**Features :** Grinding attachment for lathe machine available in 150 mm to 300 mm stone dia. & 0.5 HP to 5 HP motor capacity.

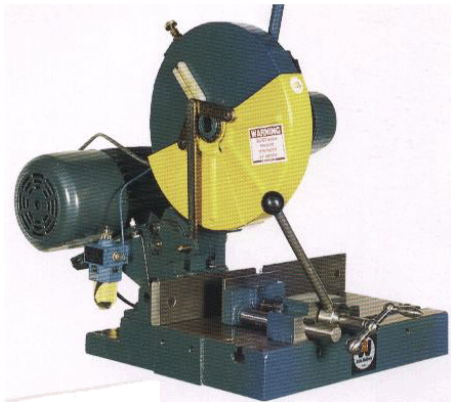

#### **DISC CUT-OFF**

**Features :** Abrasive wheel fitted Cut-Off machine available from 200 mm to 600 mm disc size and 1 HP to 10 HP motor capacity. Vice with degree setting fitted onto base.